

CURB RAMP DETECTABLE WARNING DETAIL

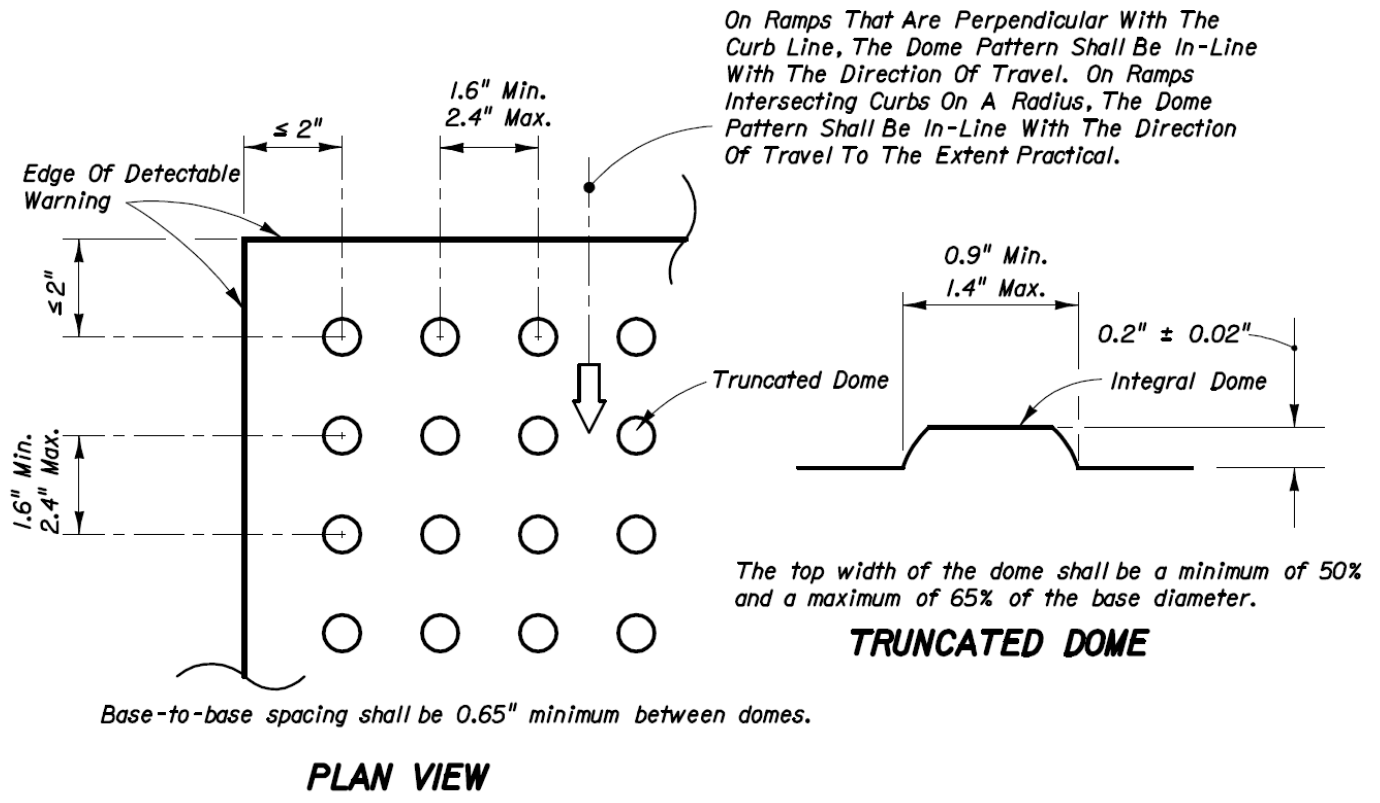

All Sidewalk Curb Ramps Shall Have Detectable Warning Surfaces That Extend The Full Width Of The Ramp And In The Direction Of Travel 24 Inches (610 mm) From The Back Of Curb.

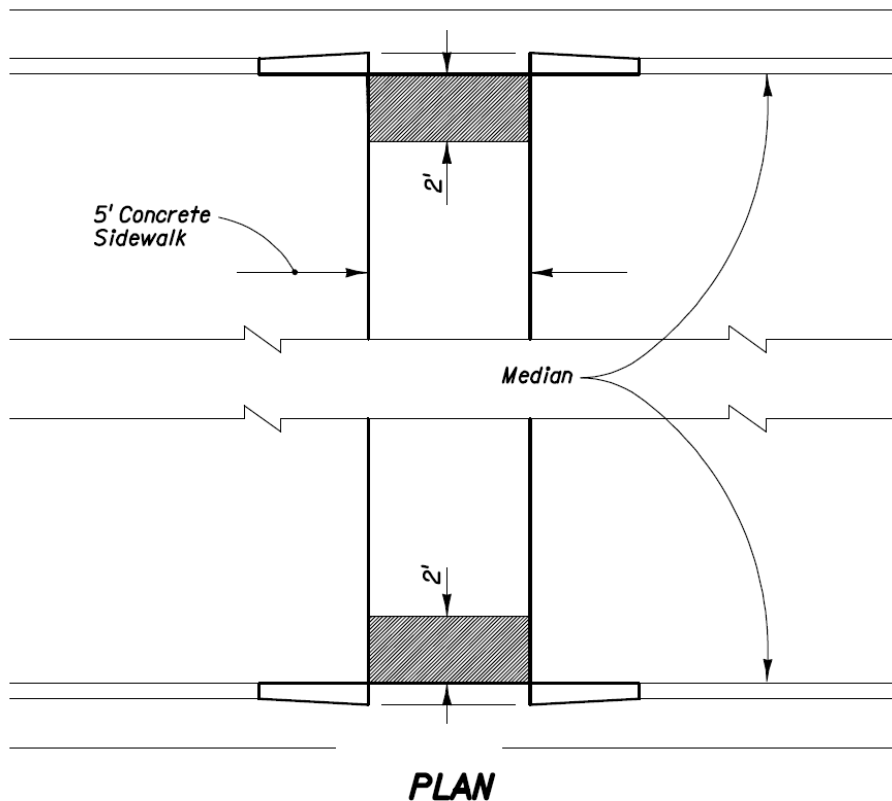

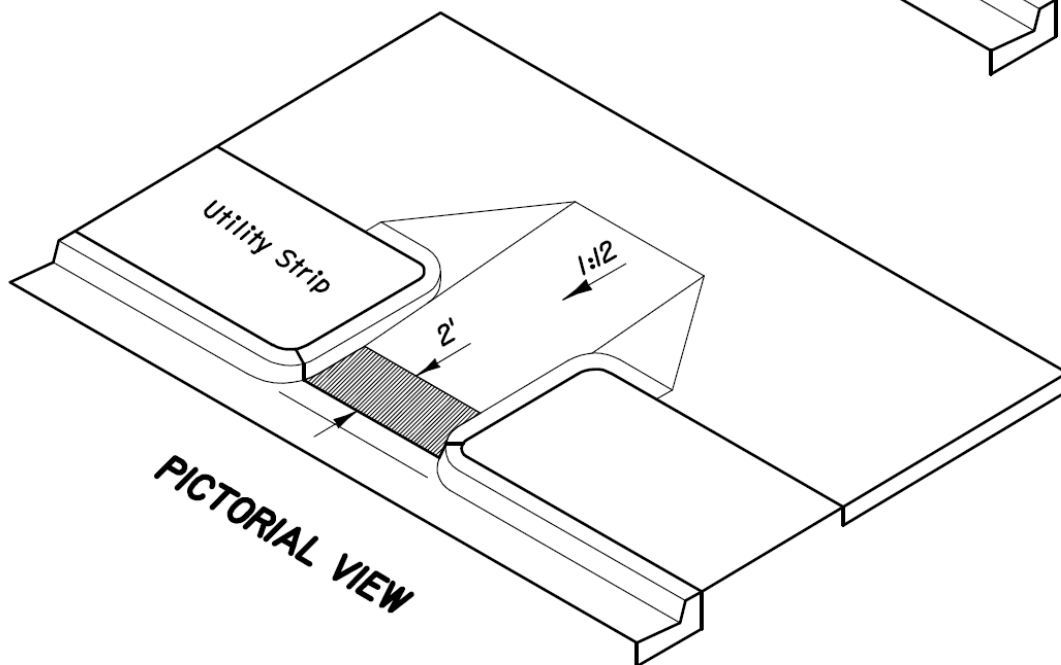
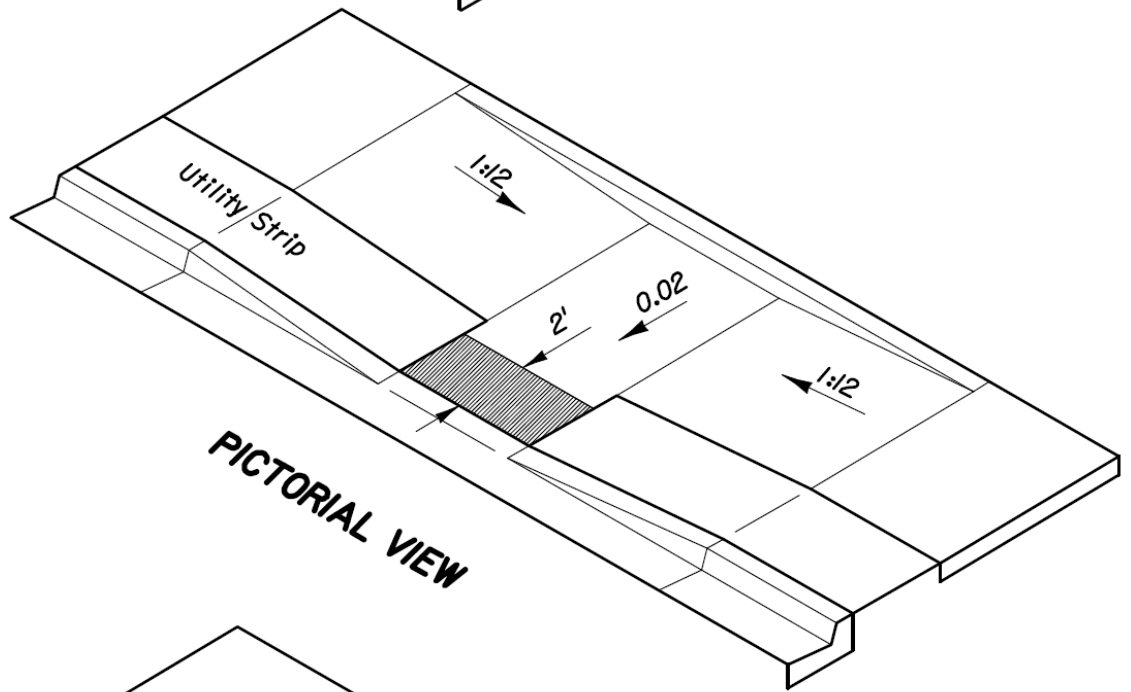
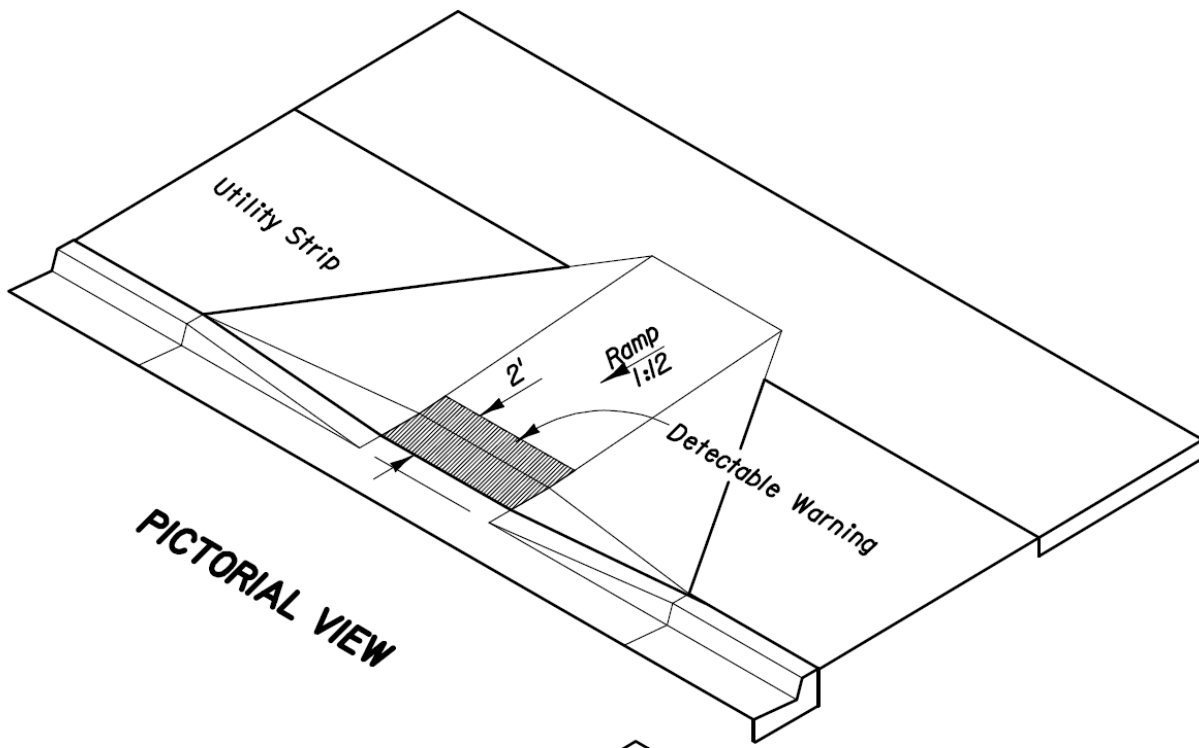

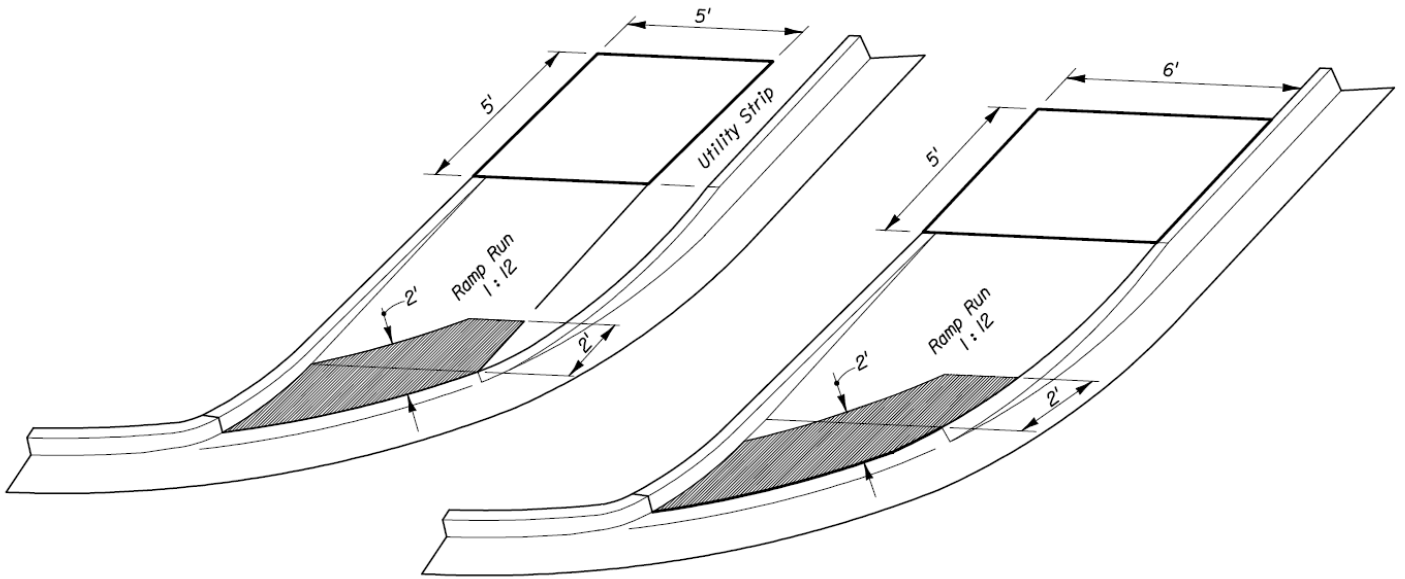

PICTORIAL VIEWS

TYPICAL PLACEMENT OF DETECTABLE WARNING ON CURB RAMPS

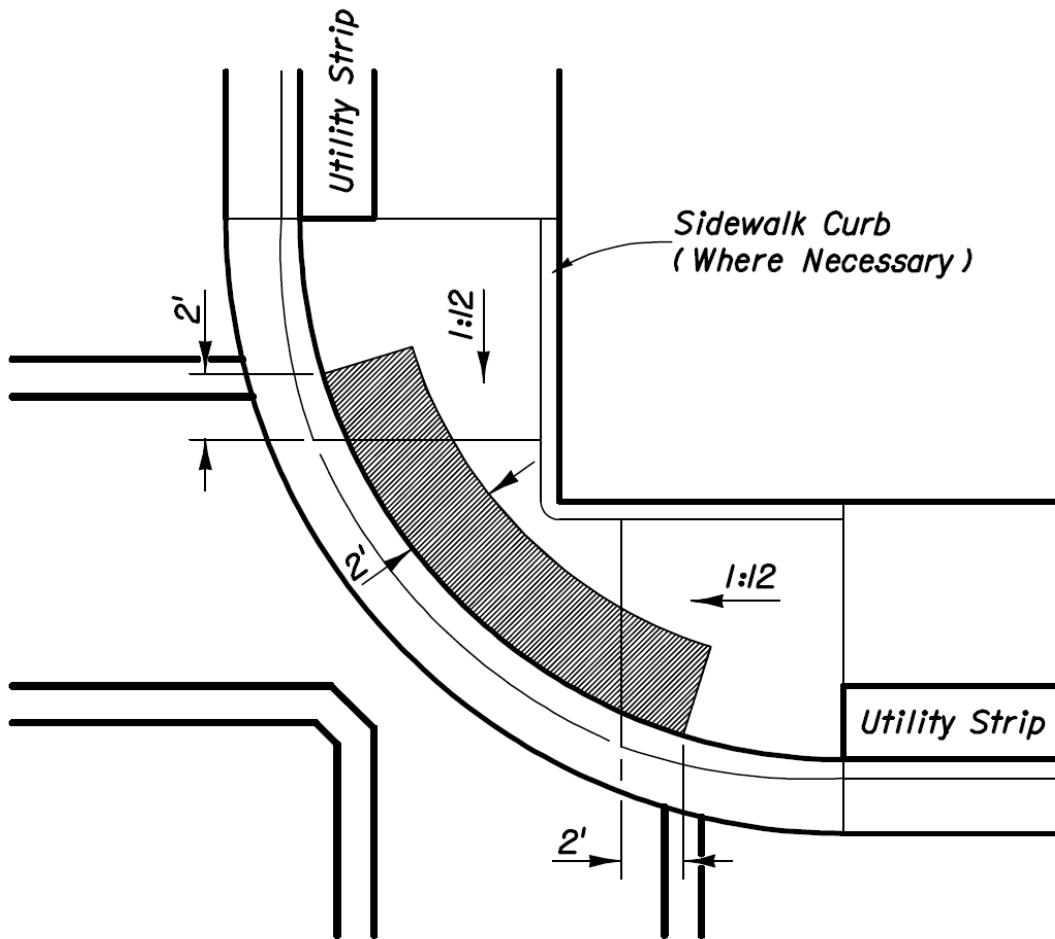

PLAN